



# **Sound xR Image on DME and Nuendo Connection Guide**

**Version 1.0.0**

This specification document applies to DME Firmware V3.00 and later.

## Table of contents

<b>0. Revision History</b> .....	<b>2</b>
<b>1. Introduction</b> .....	<b>3</b>
<b>2. Preparation</b> .....	<b>3</b>
2.1. Required Software and Devices .....	3
2.2. Connection Procedure .....	3
2.3. DME Configuration.....	3
2.4. Configuring a Laptop Running Nuendo.....	4
<b>3. Nuendo Settings</b> .....	<b>5</b>
3.1. Pre-Configuring Nuendo .....	5
3.2. External OSC Renderer Setup.....	5
3.3. Creating Audio Tracks .....	6
3.4. Linking Audio Tracks and Object Buses .....	6
<b>4. Audio Routing Between Nuendo to DME</b> .....	<b>8</b>

## 0. Revision History

Version	Date	Section	Description
V1.0.0	Feb. 17, 2026	-	Initial version

## 1. Introduction

Steinberg Nuendo digital audio workstations support Sound xR Image control. This guide explains how to control sound objects of Sound xR Image on DME using Nuendo's standard VST Multipanner.

To control Sound xR Image sound objects, the following settings are required on Nuendo.

1. Setting the External OSC Renderer
2. Creating Audio Tracks
3. Linking Audio Tracks and Object Buses

### NOTE:

**External OSC Renderer:** A renderer that converts VST Multipanner's pan information into Open Sound Control (OSC) signals that control the Sound xR Image, and transmits the signals.

**Object bus:** An output bus to output each sound object sound signal.

**Device port:** An audio interface output port

**Object ID:** Number corresponding to Sound xR Image's object number

## 2. Preparation

### 2.1. Required Software and Devices

- Sound xR Image Controller
- Nuendo version 11 or later
- Ethernet Port (required as a control port for a laptop running Nuendo)
- Dante compatible audio interface (connect it to a laptop running Nuendo)

### 2.2. Connection Procedure

Connect both the control network and the Dante network to a laptop running Nuendo and to the DME as follows. The control target devices are specified by their IP addresses.

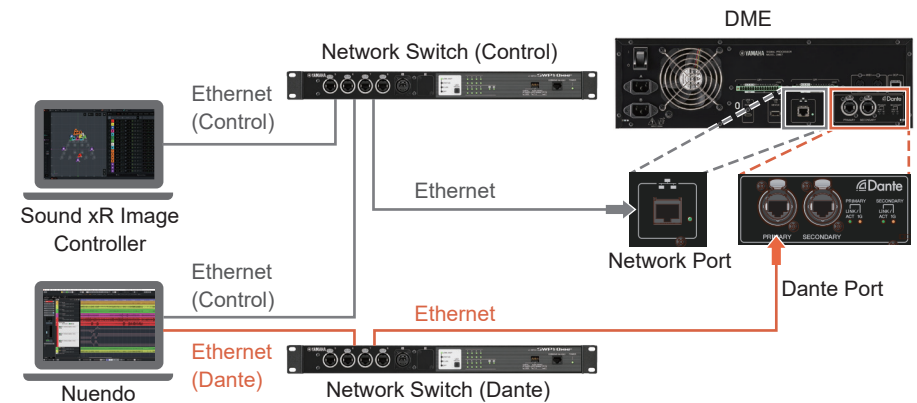

### 2.3. DME Configuration

#### IP Address Setting:

Press the MENU/HOME key on the front panel. Select Settings > IP Settings > DME Control Port, then specify the Network Mode, IP address, and subnet mask.

\* These parameters can also be set in ProVisionaire Design.



### Sound xR Image Component Settings:

Sound xR Image Parameters in DME can be controlled after creating an audio configuration that includes an Sound xR Image Component within DME, then synchronize and save that configuration to them. See the ProVisionaire Design user manual for details.

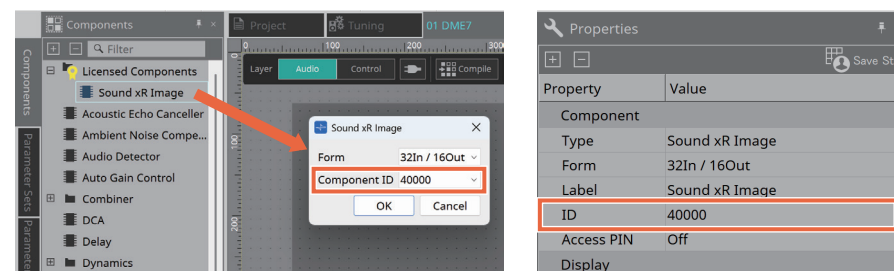
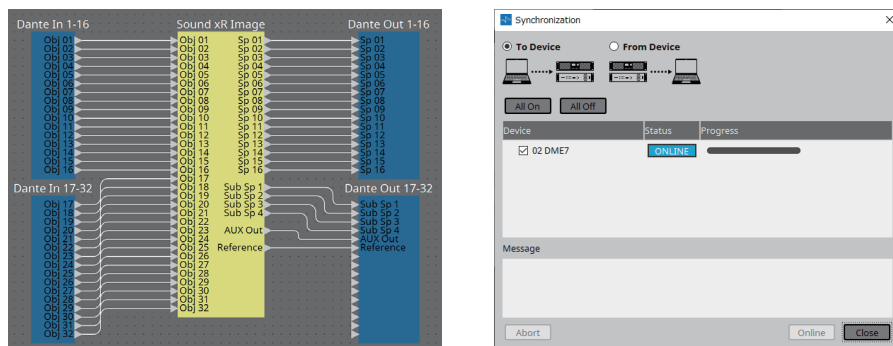

Operation checks can also be performed without a DME unit by using Sound xR Image Controller. Configure the following settings on the remote controller side for each connection:

- IP Address: Localhost (127.0.0.1) or the IP address of another laptop running Sound xR Image Controller
- IP Port No.: UDP 50528
- Component ID: 0

## 2.4. Configuring a Laptop Running Nuendo

### Dante Audio Device Setting:

Ensure the sampling frequency matches that of the DME running the Sound xR Image component. When using Dante Virtual Soundcard (DVS) on a laptop, configure the required number of channels, and then launch DVS.

### Control Port Setting:

The Sound xR Image component in the DME can be controlled from Nuendo via Ethernet (Network terminal). Configure the following settings on the remote controller side for each connection:

- IP Address: Specify the IP address of the DME Control Port
- IP Port No.: UDP 50528

The component ID of the Sound xR Image component to be controlled must also be specified in the OSC address. In ProVisionaire Design, the component ID can be confirmed or changed either when the Sound xR Image component is dragged and dropped or in the Properties area.

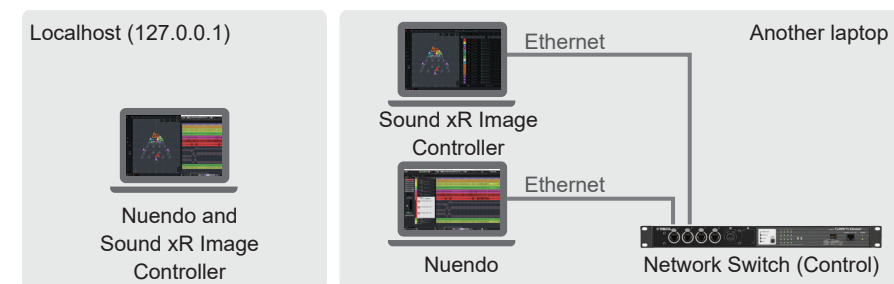

## 3. Nuendo Settings

### 3.1. Pre-Configuring Nuendo

1. Launch Nuendo and create a new project.
2. From Nuendo's top menu, select "Studio" > "Studio Setup", and select the audio interface configured in Chapter 2 (in this case, DVS) on the Audio System field.

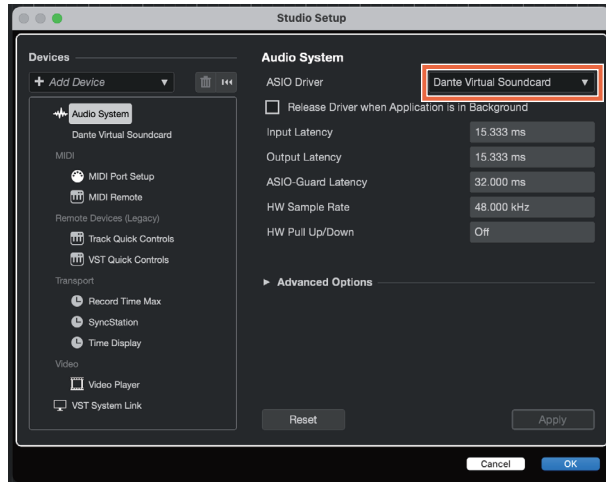

3. From Nuendo's top menu, select "Studio" > "Audio Connections" and click the "Outputs" tab.
4. Delete all buses created by default and create an audio bus which has three-dimensional panning information (in this case, 7.1.4-channel buses). Do not assign the audio interface device ports to the buses at this stage.

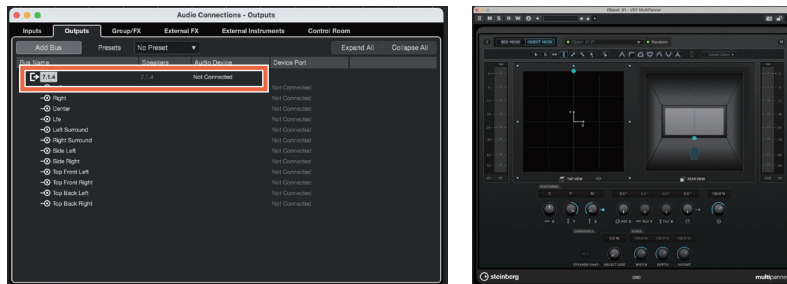

### 3.2. External OSC Renderer Setup

1. From Nuendo's top menu, select "Studio", > "External OSC Renderer Setup."
2. Enter the following information in the Network section.
  - OSC Data Transmission: Activate
  - IP Address: IP address of network port or DME or a laptop running Sound xR Image Controller (Use 127.0.0.1 if Sound xR Image Controller is running on same laptop)
  - Port Number: 50528
  - Header: /yosc:req/set/PROC:Component/*Component ID*/OBA/Object/LogicalPosition (Enter the Component ID, such as 40000, which corresponds to the ID of the Sound xR Image component in the DME)
  - Touch Messages: Disable
  - Normalized Position: Enable
3. In the Device Port Mapping section, configure which object IDs are assigned to which output channels of the connected audio device. It is recommended to align the object IDs with the output channels. By clicking "Map All", all output channels are automatically assigned to their corresponding object IDs.

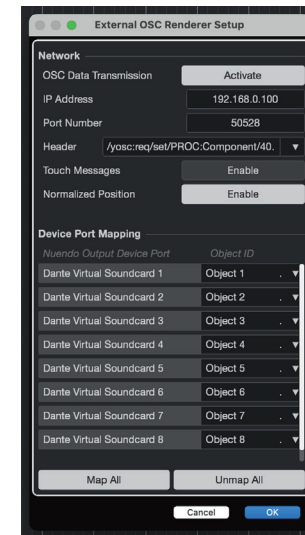

### 3.3. Creating Audio Tracks

Add audio tracks that match the configuration of the audio file (for example, mono or stereo). At this stage, to enable the use of VST Multipanner on the added audio tracks, select the output bus (for example, the 7.1.4 output bus created in Section 3.1) in Audio Outputs.



### 3.4. Linking Audio Tracks and Object Buses

1. From Nuendo's top menu, click "Project" > "ADM Authoring...".
2. Enter the following information:
  - Format: OSC (external)
  - Auto-Connect Object Buses: Checked (recommended)
3. Click "Add Objects".
4. In the Source Track section, select the audio track to be assigned to an object. After selection, an Object Bus is created automatically and an Object ID is assigned. The audio track associated with the assigned Object ID is output from the output device port specified in Device Port Mapping of External OSC Renderer Setup configured in Section 3.2.

#### NOTE

- If the audio interface is not working properly, object IDs may not be correctly assigned.

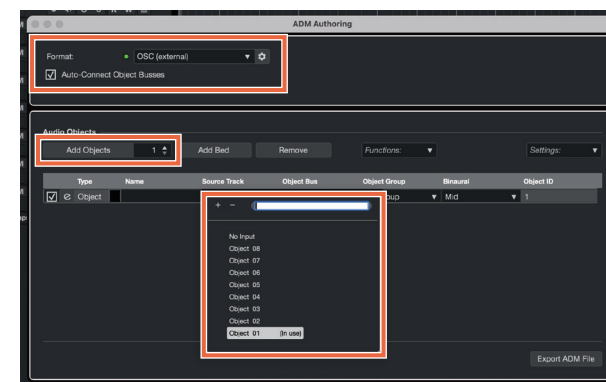

5. To simultaneously create Object Buses and assign Object IDs to multiple audio tracks, select the audio tracks you wish to assign to objects, then click "Create Objects from Selected Tracks" from the "Functions:" dropdown menu. This will automatically assign object IDs to the selected tracks in sequential order.

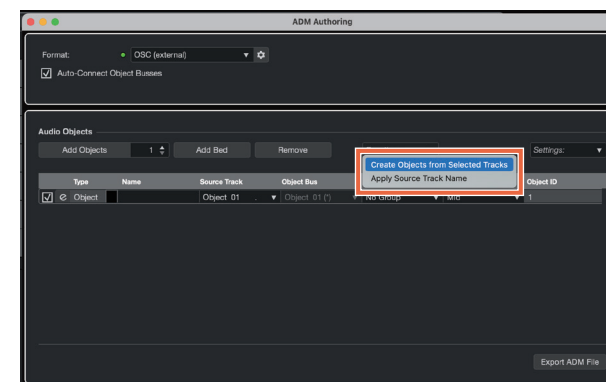

6. Close the window.
7. Confirm that changes in VST Multipanner are reflected in the position of Sound xR Image.

8. From Nuendo's top menu, select "Studio" > "Audio Connections", click the "Outputs" tab, and verify that output buses corresponding to each audio track have been created.

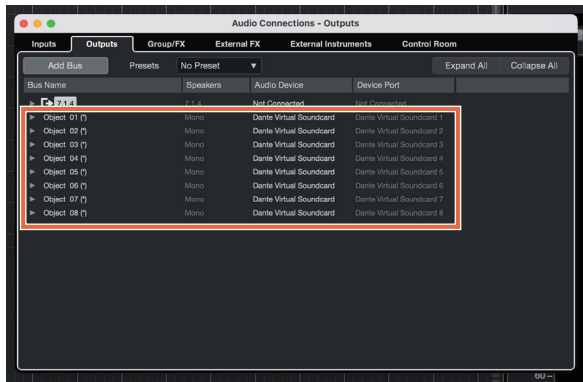

## 4. Audio Routing Between Nuendo to DME

Using Dante Controller, configure the audio routing between the laptop running Nuendo and the DME device where the Sound xR Image configuration was created. Please be sure to route the input ports of the DME to the Dante Inputs connected to the Sound xR Image components.

