

DME10

Reference Manual

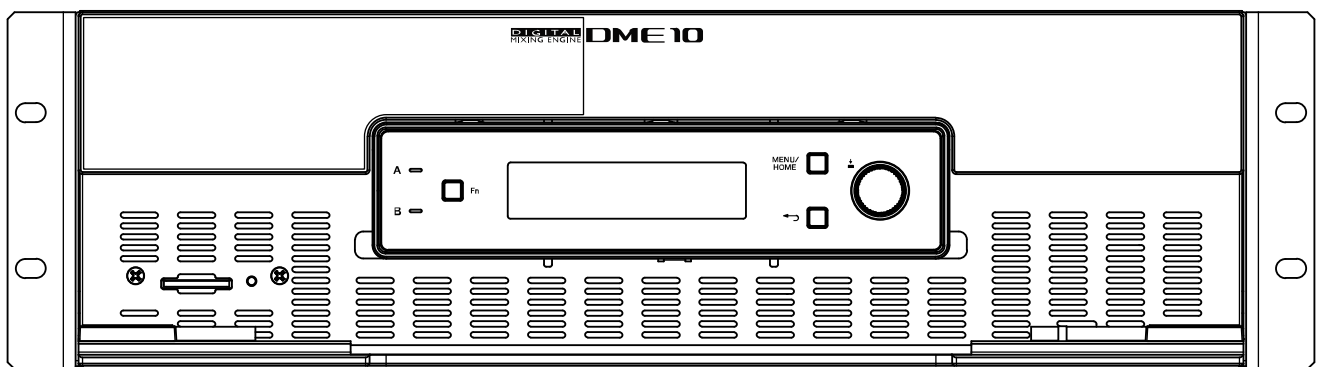

SIGNAL PROCESSOR

Table of contents

Introduction	3
About the symbols	3
About copyrights	3
About this manual	3
Features	4
Package contents (please verify)	4
Available documentation	4
About Yamaha ProVisionaire Design	5
About Yamaha Sound xR Image	5
About Yamaha Steinberg USB Driver	5
Updating the firmware	5
Precautions for rack mounting	6
Part names and functions	7
Front panel	7
Rear panel	9
Making connections	12
Connecting to the [GPI] ports	12
Connecting a Euroblock plug	12
Installing the cable hook	14
About Dante	15
About connection	16
Power supply	19
Connecting the power supply	19
Switching on/off this device	19
Panel operation	20
Basic operations	20
Muting/Unmuting (Device Mute screen)	21
Enabling/disabling the control function (Control Function screen)	22
Alert screen	22
Panel lock	22
Screens	24
Home screen	24
[Menu] screen	25
Screen flowchart	26
Input Meter/Output Meter	27
Reading the meter	27
Device Information	28
Sampling Frequency	28
License	28
System Date	28
QR Code	28
MAC Address	28
Serial No.	29
Dante Version	29
Firmware Version	29
Alert Log	30
Clearing the log	30
Utility	31
Panel Setup	31
Exporting/saving (Export File)	33





Selecting the language (Language)	34
Dante Settings	35
Specifying the sampling frequency (Sample Rate)	35
Specifying the preferred leader (Preferred Leader)	35
Specifying the encoding (Encoding)	35
Specifying the latency (Latency)	35
Specifying the secondary port (Secondary Port)	36
Settings	37
Specifying the unit ID (Unit ID)	37
Specifying the IP address (IP Settings)	38
Restoring factory default settings (Initialize Settings)	39
Restarting (Reboot)	39
Snapshot Recall	40
Restoring factory default settings (initializing)	41
Method of selecting [Settings] > [Initialize Settings]	41
If you have forgotten your administrator PIN	42
Appendix	43
Precautions for the USB port	43
Using USB flash drives	43
Precautions for using SD memory cards	44
Using SD memory cards	44
Distance to furthest DCP control panel	45
Message List	46
General specifications	53
Dimensions	55
Block diagram	56

Introduction

Thank you for purchasing a NEXO DME10 signal processor. This device can process a wide range of audio signals for facility acoustics. This Reference Manual provides explanations for everything necessary to configure settings and operate the system. In order to take full advantage of the various functions of this device, consult this Reference Manual whenever necessary.

About the symbols

The symbols on this device and in this manual have the following meanings.

Symbol	Meaning
 Warning	This indicates a risk of serious injury or death.
 Caution	This indicates a risk of injury.
 Notice	This indicates a risk of product failure, damage or malfunction as well as data loss.
 NOTE	This indicates content regarding operation and use. Read this for your information.

About copyrights

- Copying of the software or reproduction of this manual in whole or in part by any means is expressly forbidden without the written consent of the manufacturer.

About this manual

- The illustrations and screens in this manual are for instructional purposes only.
- NEXO S.A. make no representations or warranties with regard to the use of the software and documentation and cannot be held responsible for the results of the use of this manual and the software.
- Windows is a registered trademark of Microsoft Corporation in the United States and other countries.
- “QR Code” is a registered trademark of DENSO WAVE INCORPORATED.
- The company names and product names in this document are the trademarks and registered trademarks of their respective companies.
- Updates to the software may become available without prior notice.

Features

- **Programmable signal processor for audio systems in a wide variety of applications**

The DME10 is a highly configurable processor that offers sophisticated functionality and outstanding quality audio for use in a wide variety of applications. In addition to basic matrix mixing, equalizing, delay, compressor, and gate functionality, it also includes many components that support a variety of applications, such as Automixer and Room Combiner. It also supports large-scale audio systems with 256 × 256 channels of Dante inputs and outputs.
- **Yamaha ProVisionaire Design application software enables you to design a complete audio system.**

ProVisionaire Design application software enables you to program various DME10 audio processing functions. It also allows you to design a complete integrated audio system, including inputs/outputs and amplifiers.
- **Yamaha Sound xR Image Controller application software can create an immersive sound environment in any space.**

Sound xR Image Controller application software can be used to set up and control an Sound xR Image system.

It can create an immersive acoustic experience by allowing users the flexibility to control the perceived position of sound images within a space in a broad variety of applications, such as theaters, opera halls, concert venues, sound installations, and theme parks.
- **Support for Yamaha's external controls**

The DME10 supports all DCP wall-recessed control panels. It also supports the ProVisionaire Control PLUS app for Windows, which can be used to customize designs. The DME10 also supports customizing operating environments based on specific equipment applications. ProVisionaire Control PLUS enables you to output to the ProVisionaire Kiosk app for Windows and iOS and use it as a dedicated app for on-site operation.

Package contents (please verify)

- One Setup Guide
- Two Euroblock plugs (16-pin, 3.50 mm pitch)
- Two power cords
- One cable hook

Available documentation

- **DME10 Setup Guide (included with this device)**

Describes the setup procedure from connecting the power supply to setting up the system.
- **DME10 Reference Manual (this document)**

Explains everything necessary for configuring settings and operating the system.
- **[Yamaha ProVisionaire Design User Guide \(HTML\)](#)**

Describes how to operate the ProVisionaire Design software used to control this device from a computer.
- **[Yamaha Sound xR Image Controller User Guide \(HTML\)](#)**

Explains how to operate Sound xR Image Controller software to control Sound xR Image, a purchasable component, from a computer.

About Yamaha ProVisionaire Design

This Windows application software integrates settings for devices such as signal processors, power amplifiers, and audio interfaces.

Download ProVisionaire Design from the following website.

<https://www.yamahaproaudio.com/>

For details, refer to the [ProVisionaire Design User Guide \(HTML\)](#).

About Yamaha Sound xR Image

This is a sound image control system that enables immersive acoustic production in a wide variety of applications, including theaters, opera halls, concert venues, and other installations.

Visit the following website to download Sound xR Image Controller application software that can be used for sound image control.

<https://www.yamahaproaudio.com/>

Refer to the [Sound xR Image Controller User Guide \(HTML\)](#) for more information.

About Yamaha Steinberg USB Driver

This driver software is for connecting the DME10 to a computer via USB.

Up to 8 input/8 output audio signals can be exchanged with DAW software.

The driver software can be downloaded from the following website.

<https://www.yamahaproaudio.com/>

Updating the firmware

This device is designed to allow its firmware to be updated for the purpose of improving operability, adding functionality, and fixing bugs.

When a firmware update is available, relevant information will be posted on the following website.

<https://www.nexo-sa.com/>

For details on the updating procedure and device settings, refer to the ProVisionaire Design User Guide (HTML).

NOTE

- The Dante firmware is updated with Dante Updater. Dante Updater can be opened from Dante Controller.
- Other devices may need to be updated, depending on the version of each device in the Dante network. For details, check the firmware compatibility chart provided on the NEXO website mentioned above.

Precautions for rack mounting

The guaranteed operating temperature range for this device is 0 to 40 °C. When multiple DME10 devices are mounted and operated on a standard EIA rack, it is not necessary to leave space between them. When this device is mounted on a standard EIA rack together with other devices, heat generated from those devices may impair performance due to the elevated temperature in the rack. In order to prevent heat from building up inside this device, be sure to mount it in a manner that satisfies the following conditions.

- When mounted together with a power amplifier or other devices that tend to generate heat, leave at least 1U of space between this device and other devices. In addition, in order to ensure adequate ventilation, install vented panels at those spaces or leave the spaces open.
- This device is designed to intake air at the front and exhaust it at the rear, so do not install it together with other devices that intake air at the rear and exhaust it at the front.
- Leave the rear of the rack open and the rack positioned at least 10 cm away from the wall and ceiling. If the rear of the rack cannot be left open, use a commercially available fan kit or other forced air ventilation system. If a fan kit is installed, note that closing off the rear of the rack can improve heat dissipation in some cases. For details, refer to the instruction manuals for the rack and fan kit.

Part names and functions

Front panel

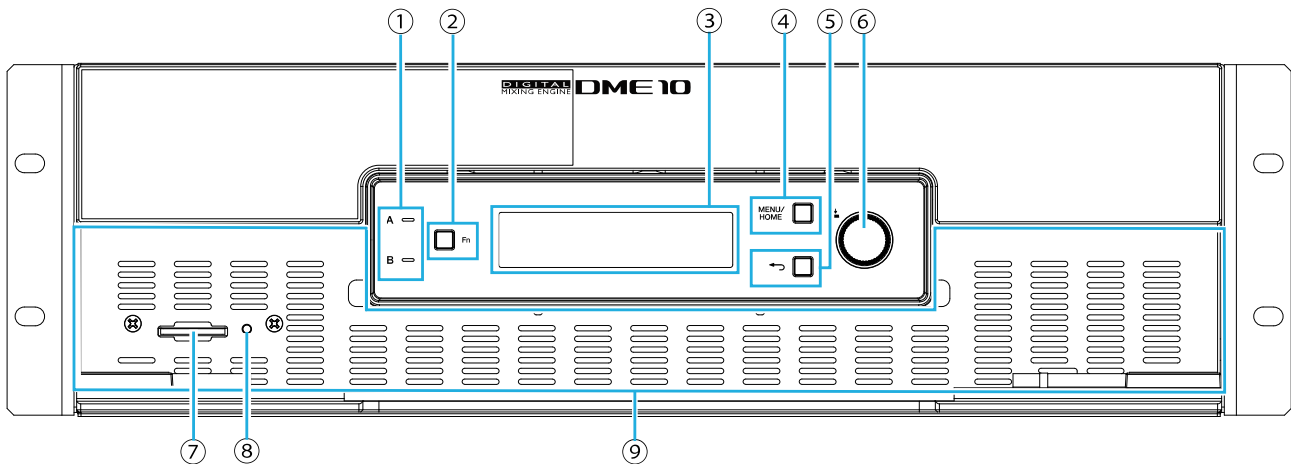

① [A]/[B] indicators

These indicate the energized state of AC IN (power inlet) jacks [A]/[B]. They are lit in green when this device is on.

② [Fn] button

Pressing this button displays the Device Mute screen. Pressing it again displays the Control Function screen.

③ Display

This shows the DME10 status or the settings menus. For details, refer to the [“screen flowchart”](#).

④ [MENU/HOME] button

This switches between the [Menu] and Home screens.

⑤ ↶ (back) button

Pressing this button displays the previous screen.

⑥ Main knob

Turning the main knob selects a parameter or changes the parameter setting. Pressing the knob confirms the selection.

⑦ SD memory card slot

Project files transferred from ProVisionaire Design or the log for this device can be exported and saved to an SD memory card. In addition, MP3/WAV files saved to an SD memory card can be played back. For details, refer to [“Using SD memory cards”](#) in the Appendix.

⑧ SD/ACT indicator

This indicator flashes while an SD memory card is being accessed.



Notice

- Do not remove the SD memory card or switch off this device while data is being accessed. Otherwise, the storage media may become damaged, or data on this device and the media may become corrupted.

⑨ **Intake vent**

Since air is taken in through here, be sure not to obstruct the intake vent.

Rear panel

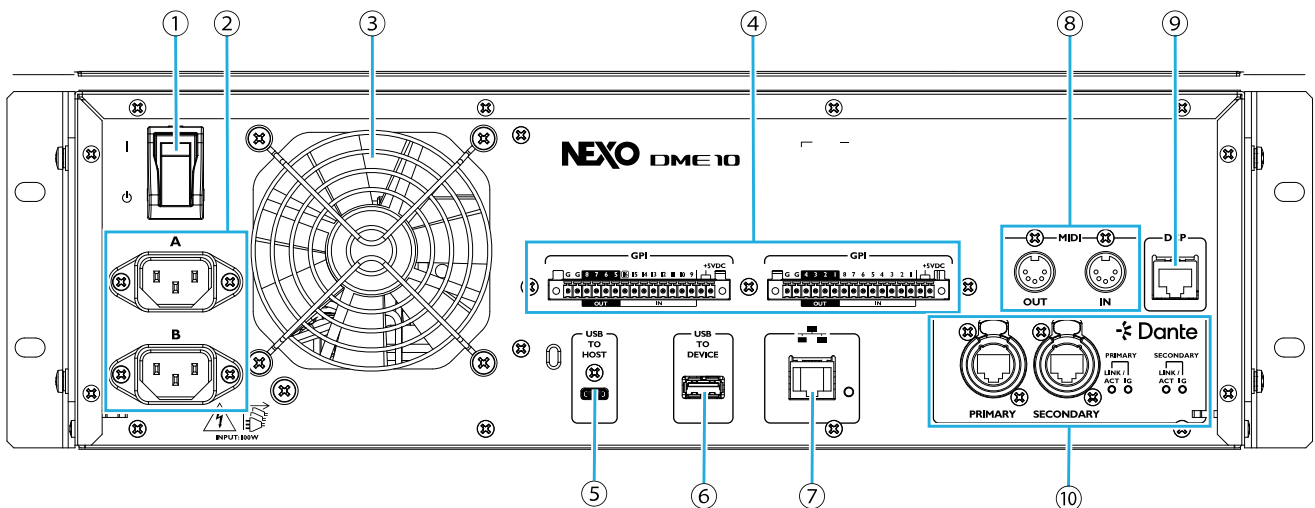

① I / ⏻ (power switch)

This switches this device on (I)/off (⏻). Before extended periods of disuse, be sure to disconnect the power cords from the AC outlets.



Caution

- Flipping the power switch on and off in rapid succession may cause a malfunction. Before switching this device on again after switching it off, wait at least six seconds.

② AC IN (power inlet) jacks [A]/[B]

Connect the included power cords here. Connect the power cord to this device, and then plug it into an AC outlet. Press the power plug latch when disconnecting the power cord.



Caution

- Be sure to switch off this device before connecting or disconnecting a power cord.

③ Exhaust vent

The DME10 is equipped with a cooling fan. Since air is exhausted through here, be sure not to obstruct the exhaust vent.

④ [GPI] ports

These are Euroblock connectors for GPI (General Purpose Interface), which input and output control signals. With GPI inputs and outputs, the DME10 can be remotely controlled from custom-made controllers and external devices. The DME10 has 15 analog/digital input terminals, 1 digital input terminal, and 8 output terminals. At [IN] terminals 1 to 15, voltages between 0 and 5 V are detected. Only at [IN] terminal 16, +24 V input is supported, and voltages between 2.5 V and 24 V are identified as high and voltages below 2.5 V as low. [OUT] terminals 1 to 8 are open collector outputs, which switch between open and ground. The output voltage of the +5 V DC terminal is 5 V.

Use the included Euroblock plug for making connections (refer to “[Connecting a Euroblock plug](#)”). For detailed connection methods and usage examples, refer to “[Connecting to the \[GPI\] ports](#)”.

**Caution**

- Do not input voltages exceeding 5 V to [IN] terminals 1 to 15. Otherwise, failure of this device may occur.

⑤ [USB TO HOST] port

This is a USB Type C (USB 2.0) port.

When connected to a computer with a USB cable, this device functions as an audio interface with up to 8 inputs/8 outputs and a maximum sampling frequency of 96 kHz.

**Notice**

- Use a USB cable of 3 m or less.
- Before connecting the USB cable again after disconnecting it, wait at least six seconds.

⑥ [USB TO DEVICE] port

This port is for connecting a USB flash drive. For details, refer to [“Using USB flash drives”](#).

**Notice**

- Do not remove the USB flash drive or switch off this device while data is being accessed. Otherwise, the storage media may become damaged, or data on this device and the media may become corrupted.

⑦ Network port

This port is for control communication with external devices. The secure copy protocol (SCP) allows communication with a computer (ProVisionaire Design, ProVisionaire Control PLUS, or ProVisionaire Kiosk) or other external controllers (AMX, Crestron, etc.).

10/100BASE-TX and Auto MDI (no mode switching) functionality is supported.

**NOTE**

- Only when using a standalone DME10 can you connect it directly to a computer with a LAN cable.

⑧ [MIDI] ports

These ports are for sending and receiving MIDI messages to and from an external MIDI device.

⑨ [DCP] port

This port is for controlling the DME10 by daisy-chaining separately sold control panels such as the DCP1V4S.

Use a straight-through CAT5e or higher Ethernet cable with all 8 contacts used.

Up to eight control panels can be connected to one DME10. Also, the distance from the DME10 to the furthest DCP control panel varies depending on the number of connected DCP units. For details, refer to [“Distance to furthest DCP control panel”](#).

**Warning**

- Do not connect a control panel to any port other than the [DCP] port of the DME10. Otherwise, a fire or malfunction may occur due to electrical incompatibility.

**Notice**

- Never connect a device other than a separately sold control panel such as a DCP to the [DCP] port. Otherwise, failure of this device or other devices may occur.

⑩ [PRIMARY]/[SECONDARY] Dante ports

These ports are for connecting I/O devices such as the Rio3224-D3 to the Dante audio network. Use cables with RJ-45 plugs that comply with Neutrik's etherCON CAT5e.

Making connections

Connecting to the [GPI] ports

Connect GPI (General Purpose Interface) devices to the [GPI] ports on the rear panel. GPI is used to input/output control signals with external devices such as controllers.

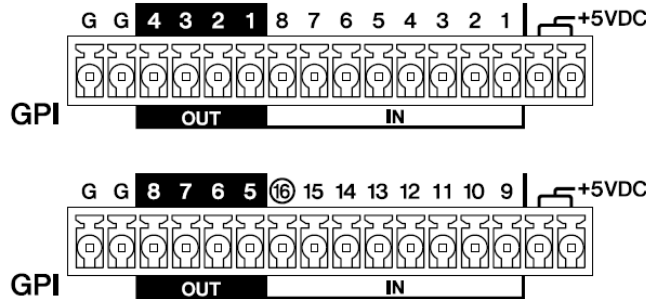

The DME10 has 16 input terminals and 8 output terminals.

- The output voltage of the +5 V DC terminal is 5 V. The maximum total current that can be drawn from the two ports is 100 mA.
If a switch/variable resistor and an LED/relay are to be used at the same time, connect the switch/variable resistor to one port and the LED/relay to the other port.
- At [IN] terminals 1 to 15, voltages between 0 and 5 V are detected. Only at [IN] terminal 16, +24 V input is supported, and voltages between 2.5 V and 24 V are identified as high and voltages below 2.5 V as low.
- [OUT] terminals 1 to 8 are open collector outputs, which switch between open and ground. The maximum voltage that can be applied is +12 V. The maximum allowable current is 75 mA per port.
Use ProVisionaire Design to specify settings such as parameters to be assigned to GPI controllers.

NOTE

- Specifying input/output channels in ProVisionaire Design allows presets from a connected GPI external device to be recalled, parameters to be changed, and signals to be sent to GPI external devices. For details on specifying settings, refer to the ProVisionaire Design User Guide.
<https://manual.yamaha.com/pa/pv/pvd/>

Connecting a Euroblock plug

Use the included Euroblock plugs to connect to the [GPI] ports.

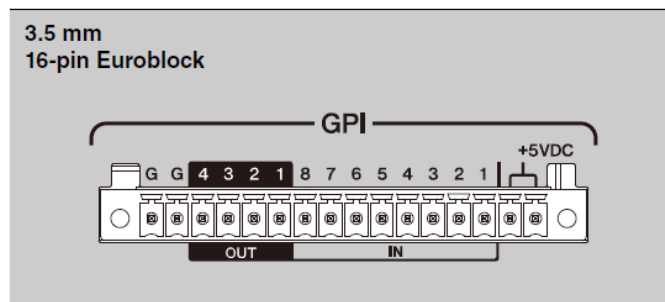

Preparing cable wires

The cable wires to be connected to the Euroblock plug should be stripped as shown and twisted. Note that the cable wire strands connected to Euroblock plugs may easily break due to metal fatigue caused by the weight of the cable or vibration.

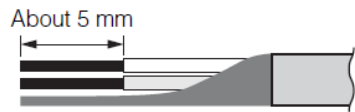

Caution

- Do not apply solder to stranded wires.

If wires will be frequently disconnected and reconnected as in a portable setup, the use of pin terminals with insulation sleeves is recommended. Use pin terminals with a conductor portion as shown below. With an outer diameter of 1.3 mm or less and a length of about 5 mm (such as A10, 5-6WH manufactured by Phoenix Contact)

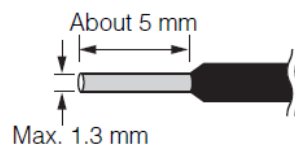

1. Push in the Euroblock plug until it is firmly seated in the [GPI] port on this device, and then raise the left and right locks.

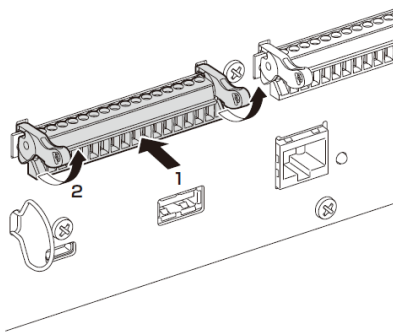

2. To remove a Euroblock plug, lower the left and right locks, and then pull out the plug.

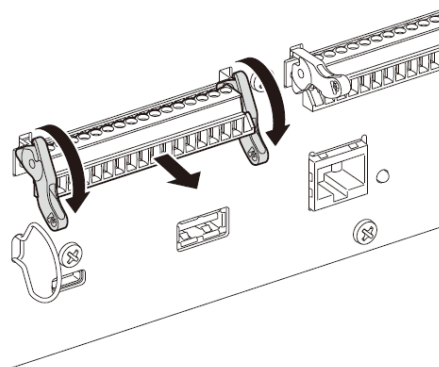

Installing the cable hook

A cable hook is provided to prevent accidental disconnection of the USB cable. To attach the cable hook, follow the steps below.

1. Hook one end of the included cable hook onto the lower end of the security slot, located in the lower-left area of the rear panel.

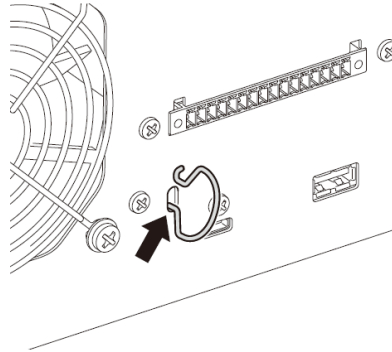

2. Insert the other end of the hook into the upper end of the security slot.

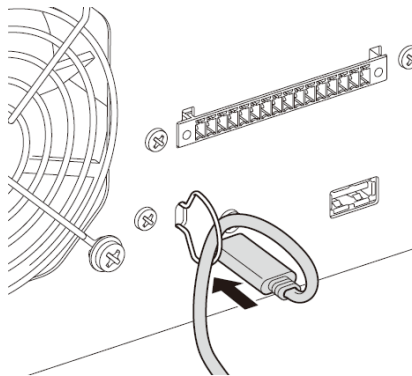

3. Insert the USB cable through the hook, and then connect it to the USB port.

About Dante

■ Overview of Dante

The DME10 transmits digital audio signals by using the Dante protocol. Dante is a network audio protocol developed by Audinate. In a network environment compatible with Gigabit Ethernet, Dante has the advantage of being able to transmit multiple audio signals with different sampling frequencies/bit rates as well as device control signals within the same network.

For details on Dante, refer to the Audinate website.

<http://www.audinate.com/>

In addition, a variety of information about Dante can be found on the Yamaha Pro Audio website.

<https://www.yamahaproaudio.com/>

NOTE

- With a Dante network, do not use the EEE function* of the network switch.
The EEE function may deteriorate the clock synchronization performance and interrupting audio. Therefore, please note the following.
 - When using managed switches, turn off the EEE function on all ports used for Dante. Do not use a switch that does not allow the EEE function to be turned off.
 - When using unmanaged switches, do not use switches that support the EEE function. In such switches, the EEE function cannot be turned off.
- *EEE (Energy-Efficient Ethernet) function: Technology that reduces the power consumption of Ethernet devices during periods of low network traffic; also known as Green Ethernet or IEEE802.3az

NOTE

- The DME series, when combined with Yamaha network switches, automatically configures the switch settings for optimal Dante performance.
Setting items: QoS, IGMP snooping, flow control disable, EEE disable, etc.
For details on the switch, refer to below.
<https://www.yamaha.com/2/how-to-choose-a-network-switch/>

About connection

There are two methods of connecting this model to a Dante network, and they can be used in combination.

Redundant connection

A redundant connection allows you to build a system that is more resistant to network failures than a daisy-chained network. A redundant connection consists of two circuits, a primary (main) circuit and a secondary (sub) circuit. Communication normally occurs on the primary circuit, but automatically switches to the secondary circuit if a problem occurs, such as the primary circuit being disconnected.

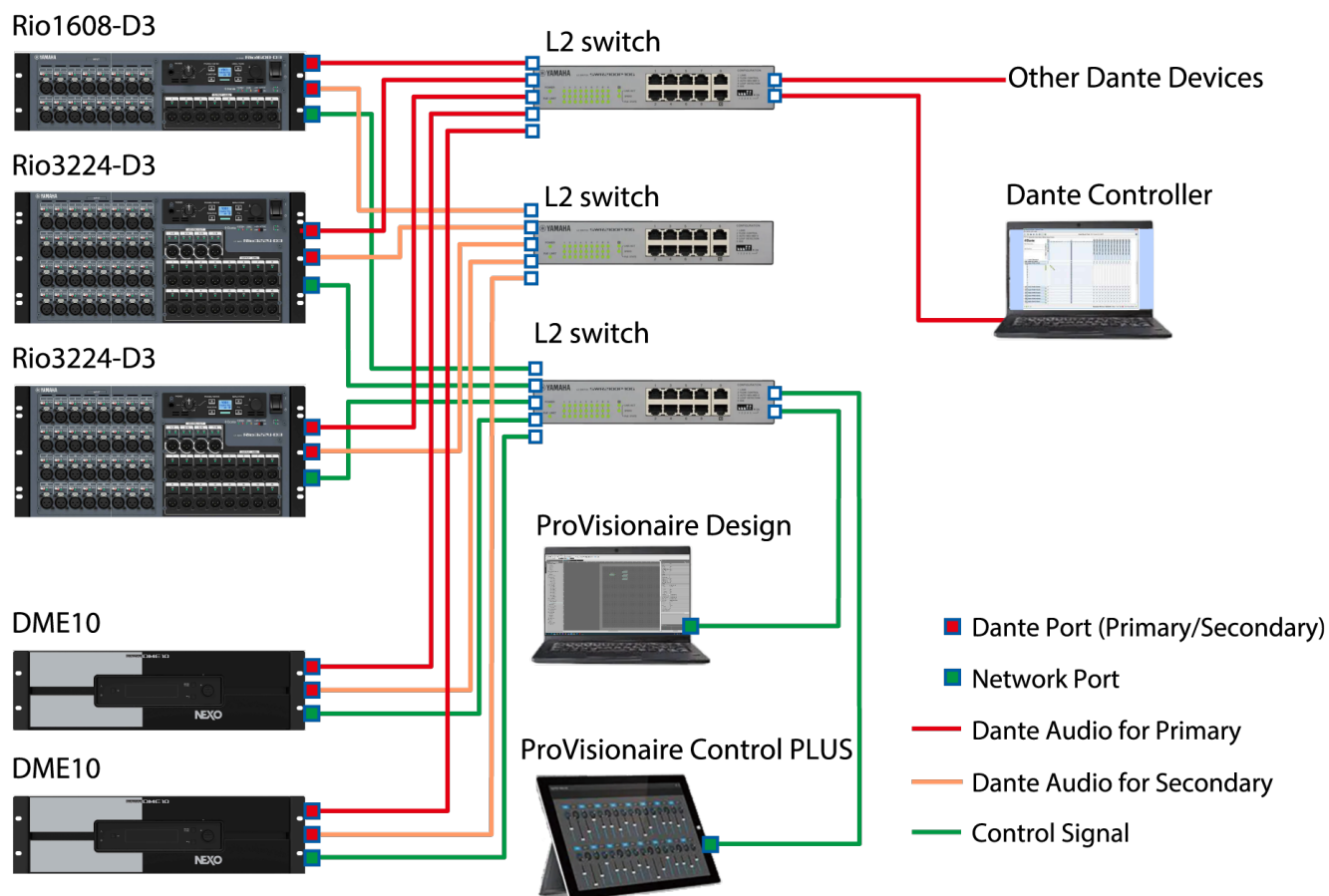

NOTE

- If you wish to run Dante audio network and ProVisionaire Design's network on the same computer, connect them using separate network interface cards.
- The above illustration assumes that the SEC.PORT (Dante secondary port) setting is set to REDUNDANT for all Rio-D3s.

Daisy-chain connection

A daisy chain is a connection method where devices are strung together. Building such a network is simple and the number of network switches can be reduced.

As more devices are connected, the transmission delay increases between the devices furthest apart, requiring the latency setting to be increased in order to prevent sound interruptions on the Dante network. Moreover, if a system failure occurs due to a broken cable, etc., the network will be interrupted at that point, making transmission with devices beyond that point impossible.

With the latency set to the default (1.0 msec), up to ten Dante devices can be connected in a daisy chain. If eleven or more devices are connected, the communication delay within the network will increase, possibly causing interruptions in the sound. In order to avoid this, either increase the Dante latency setting or use an L2 switch (Gigabit Ethernet compatible) to split the network.

NOTE

- Do not connect more than one port to the same external switch since this would create a network loop.
- The following illustration assumes that the SEC.PORT (Dante secondary port) setting is set to DAISY CHAIN for all Rio-D3s.

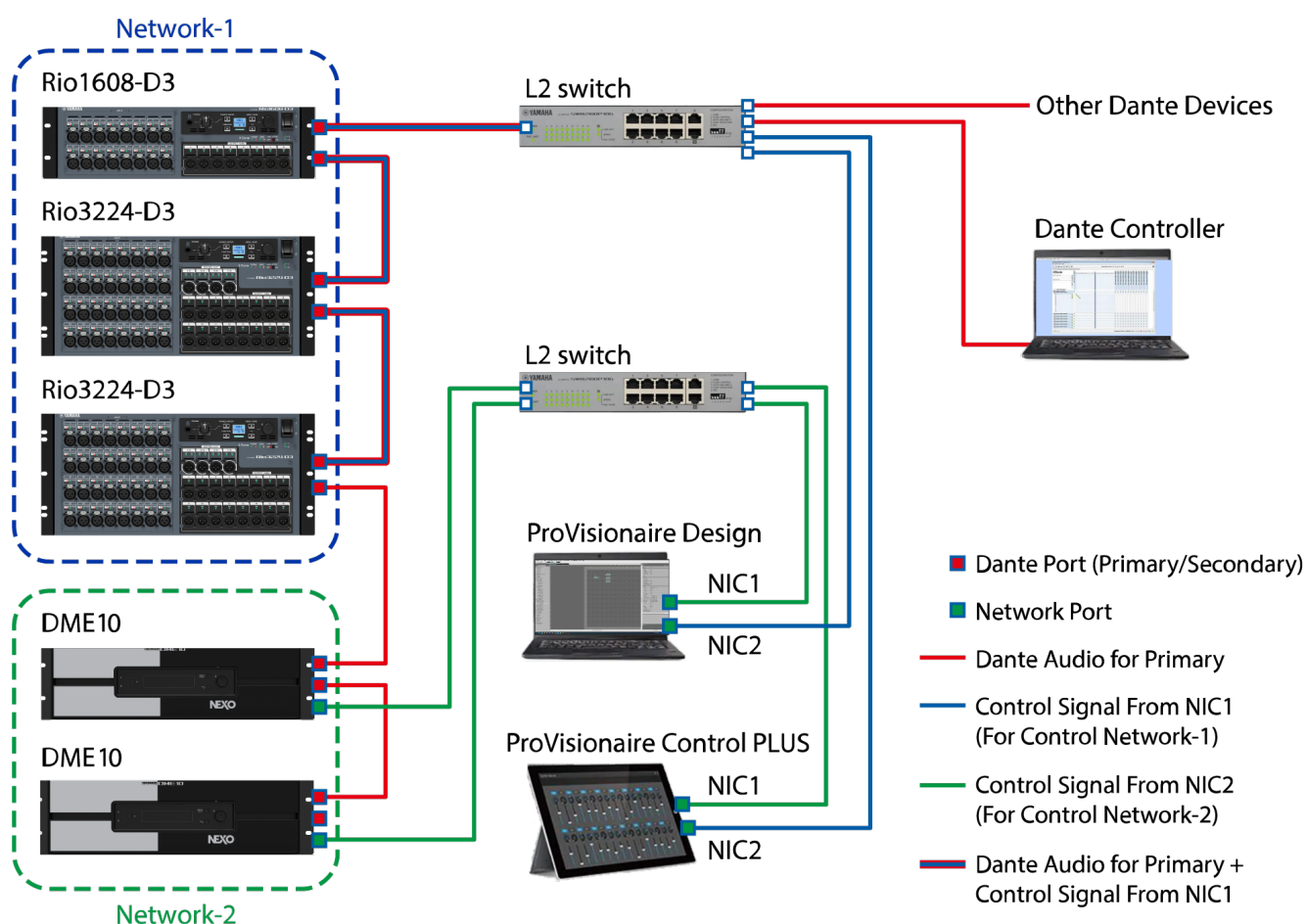

The appropriate latency setting for signals sent and received over a Dante audio network differs depending on the connection method and scale. The following is an explanation of how to select the [Latency] setting based on the connections between Dante-compatible devices and the DME10.

■ Relationship between latency and hop count

The [Latency] setting for the Dante audio network depends on the hop count in that network.

The hop count is the number of switches between the farthest connections of Dante devices. A switch is built into not only each switching hub but also each DME10 and I/O device. The hop count provides a guideline for specifying the [Latency] setting.

Typical [Latency] settings for various hop counts are shown below.

Hop count	Latency (ms)
Up to 3	0.25
Up to 5	0.5
Up to 10	1.0
Up to 20	2.0
21 or more (or if problems occur)	5.0

Power supply

Connecting the power supply

Warning

- Always use the power cords included with this device. Do not use the included power cords for other devices. Otherwise, failure, overheating or fire may occur. The included power cords are only for use in Japan (up to 125 V).

Caution

- Be sure to switch off this device before connecting or disconnecting a power cord.

1. **Connect the included power cords. Connect the power cord to this device, and then plug it into an electrical outlet.**

NOTE

- To disconnect a power cord, reverse the above procedure.
- Press the power plug latch when disconnecting the power cord.

Switching on/off this device

1. **Switch this device on (|)/off (⏻) with the power switch on its rear panel.**

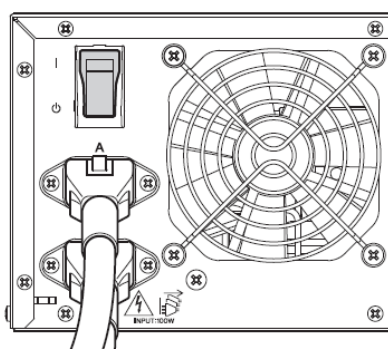

Notice

- Turning the power switch on and off quickly in succession may cause the unit to malfunction. After turning the power switch off, wait at least six seconds before turning it on again.
- A small amount of current is flowing, even when this device is switched off. Before extended periods of disuse, be sure to disconnect the power cords from the electrical outlets.

Panel operation

Basic operations

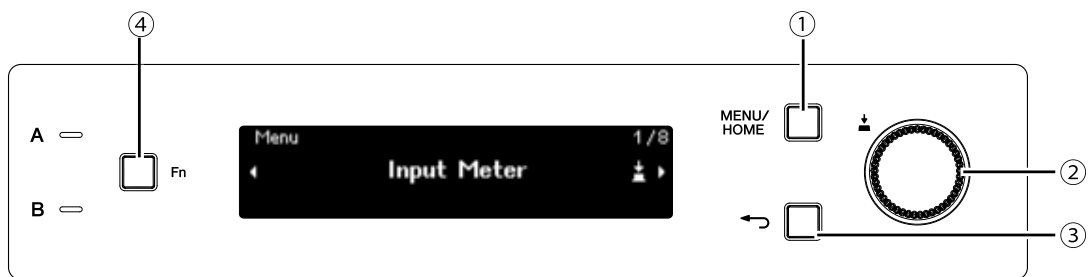

① [MENU/HOME] button

When the Home screen is displayed, pressing this button displays the [Menu] screen.

When any screen other than the Home screen is displayed, pressing this button returns to the Home screen.

② Main knob

This moves the cursor or changes parameter settings. For parameters with a wide setting range, the speed at which the knob is turned affects the speed at which the setting changes.

1. Turn the main knob to select an item. The selected item is highlighted.



2. Press the main knob to confirm the selection.



3. Repeat steps 1 and 2 to edit the desired parameter.

③ ↶ (back) button

Each press of this button moves up one level or back to the previous screen.

④ [Fn] button

Pressing this button displays the Device Mute screen.

Pressing it again displays the Control Function screen.

Muting/Unmuting (Device Mute screen)

1. Press the [Fn] button to display the Device Mute screen.



2. Turn the main knob to select [Yes], and then press the knob to confirm the selection.
If this device is already muted, a screen (shown below) appears, prompting you to confirm whether to unmute this device.



- **Canceling muting**

Press the [Fn] button again, and then follow the same procedure.

NOTE

- An icon at the top of the Home screen indicates the mute on/off status.

Enabling/disabling the control function (Control Function screen)

1. Press the [Fn] button twice to display the Control Function screen.



2. Turn the main knob to select [Yes], and then press the knob to confirm the selection.
If the control function is already disabled, a screen (shown below) appears, prompting you to confirm whether to enable the control function.



NOTE

- An icon at the top of the Home screen indicates the control function on/off status.
- Enabling/disabling the control function operates in sync with the Control Function button in ProVisionaire Design.

Alert screen

If the DME10 malfunctions, an alert message will appear on the display. If an alert is already displayed when a higher level malfunction occurs, the alert for the higher level malfunction will appear.

To view the alert details, use your smart device, such as a smartphone, to scan the QR code indicated on the screen.

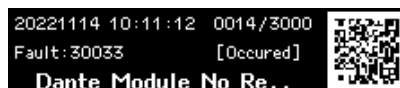

For details on each alert, refer to the ["Message list"](#).

Panel lock

Panel operation can be locked in order to prevent accidental parameter changes.

Holding down the [MENU/HOME] and  (back) buttons at the same time for at least two seconds locks the panel.

A 4-digit authentication number (called a PIN code) can be set.

Specify the PIN code by selecting Utility > Panel Setup > Enable Unlock PIN. If you have forgotten the PIN code that you set for panel lock, you can unlock the panel operation in ProVisionaire Design.

NOTE

- While the panel is locked, you can display only the Input Meter and Output Meter screens.

- **Unlocking the panel**

If the panel is operated while it is locked, the following message will appear on the display.



While the panel is locked, again holding down the [MENU/HOME] and ↶ (back) buttons at the same time for at least two seconds unlocks the panel.

If Enable Unlock PIN is set to [On], the PIN code input screen will appear.

Screens

Home screen

The Home screen appears after this device is switched on.

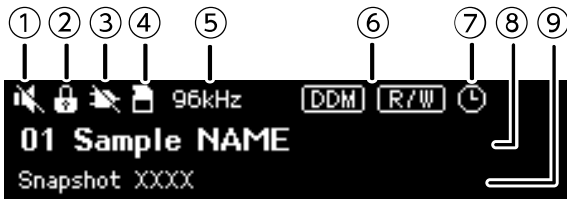

① Device Mute status indicator

This indicates the mute on/off status.



② Panel lock status indicator

A key icon appears when the panel is locked.

③ Control function status indicator

This indicates the control function on/off status.



④ SD memory card status indicator



An icon appears when an SD memory card is inserted into the SD memory card slot.

⑤ Word clock status indicator

When the word clock is locked, the sampling frequency (44.1 kHz, 48 kHz, 88.2 kHz or 96 kHz) appears. If the word clock is unlocked or if the configuration data has not been transferred from ProVisionaire Design, "Unlocked" will appear on the screen.

⑥ DDM (Dante Domain Manager) status indicators

When the device belongs to the DDM domain, the  icon appears.

The  icon (Read Write: editable) or the  icon (Read Only: not editable) appears depending on the LOCAL CONTROLLER ACCESS setting on the DDM server.

If the device belongs to the DDM domain but is not connected to the DDM server, the  icon also appears.

⑦ Scheduler status indicator

If the Scheduler has been configured, the clock icon will appear. The icon starts flashing one minute prior to the scheduled event.

⑧ Unit ID and device name

The unit ID and device name are displayed. This name can be changed in ProVisionaire Design.

⑨ Name of last recalled snapshot

[Menu] screen

The following screens can be accessed from the [Menu] screen.

- [Input Meter] screen
- [Output Meter] screen
- [Device Information] screen
- [Alert Log] screen
- [Utility] screen
- [Dante Settings] screen
- [Settings] screen
- [Snapshot Recall] screen

With the [Menu] screen displayed, turn the main knob to select the desired screen, and then press the main knob to display the respective setting or parameter.



• Moving up one level in the [Menu] screen

Press the  back button.

NOTE

- The path of the displayed screen appears at the top of the screen.

• Displaying the Home screen

With the [Menu] screen displayed, press the [HOME/MENU] button.

Screen flowchart

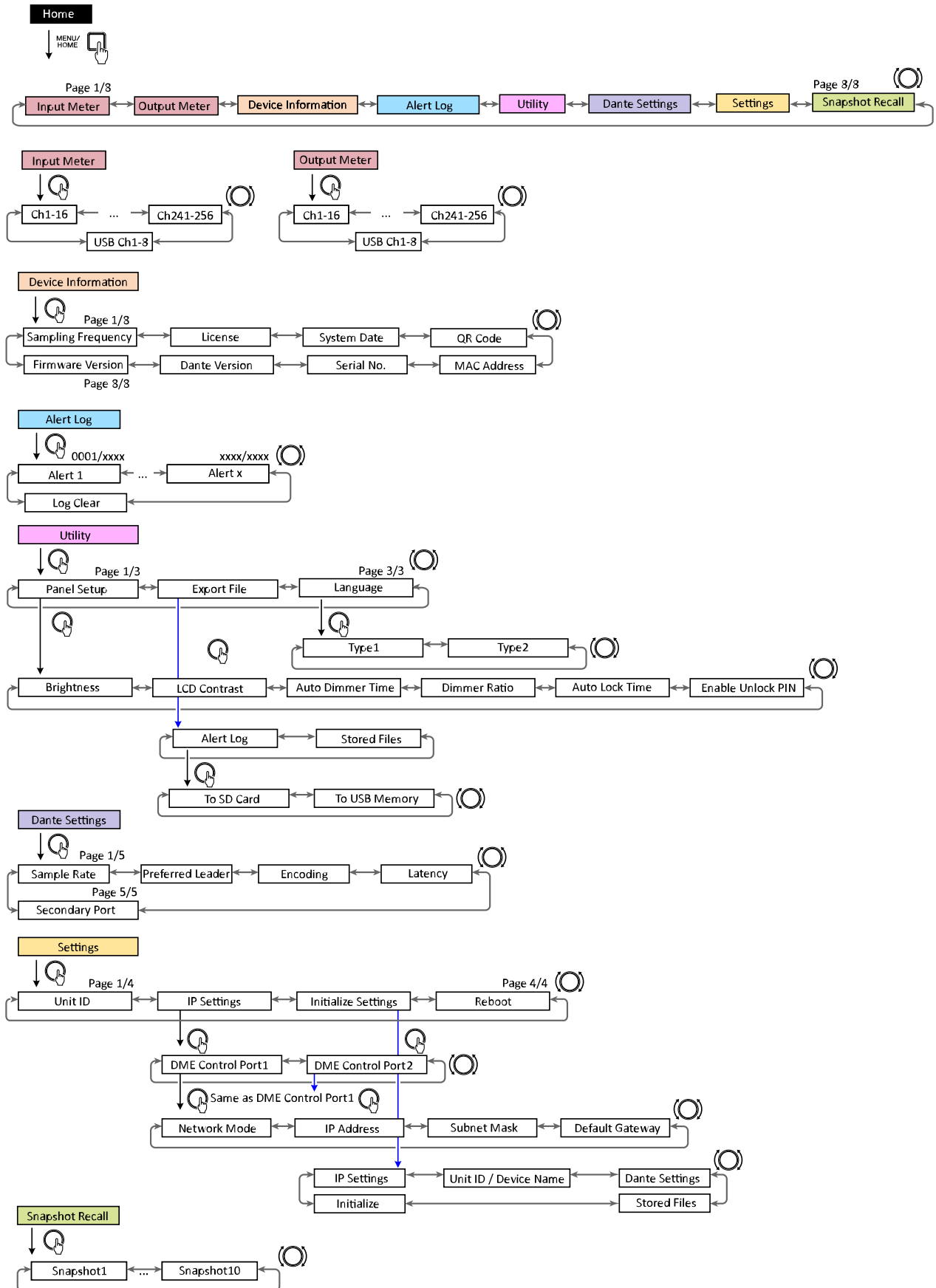

The number of snapshots will be the number sent from ProVisionaire Design

Input Meter/Output Meter

This indicates the input/output level. Dante input/output is indicated for 16 channels at a time. The number of licenses activated on this device determines the number of channels that appear in this meter.

NOTE

- While the panel is locked, you can display only the Input Meter and Output Meter screens.

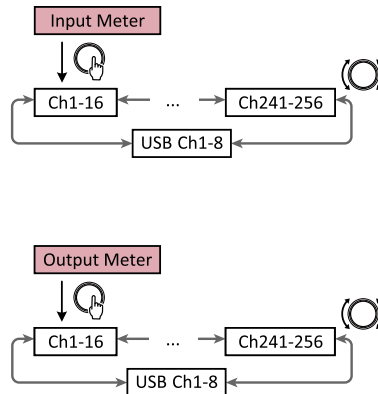

1. With the [Menu] screen displayed, turn the main knob to select [Input Meter] or [Output Meter], and then press the main knob.



2. Turn the main knob to change the displayed channels.

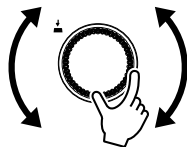

Reading the meter

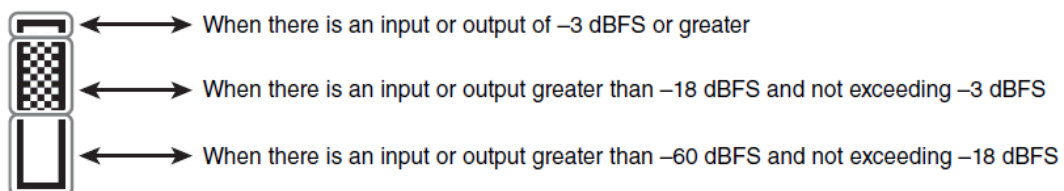

NOTE

- Peak Hold is always on; however, pressing the main knob clears the held peaks for all channels.

Device Information

This displays the status of and information specific to this device.

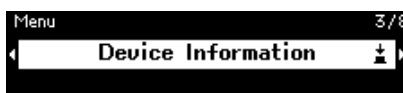
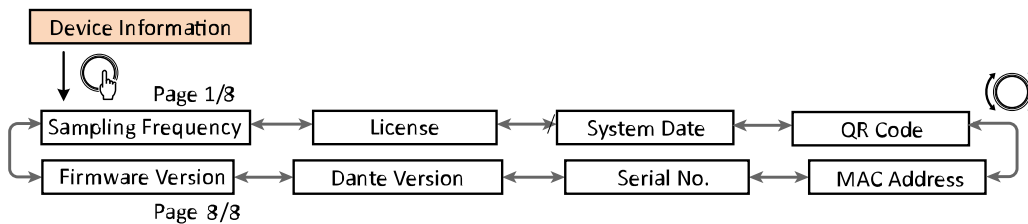

Sampling Frequency

This displays the sampling frequency. This is the frequency used when compiling a configuration with ProVisionaire Design.



License

This displays the type and number of licenses activated on this device.



System Date

This displays the date and time on the device. If the Scheduler has been configured, the clock icon will appear.

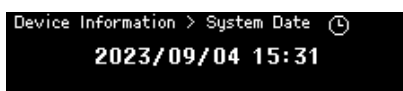

QR Code

This displays a QR code that can be scanned when activating a license.

NOTE

- For details on activating, refer to the Device License Activation Guide.

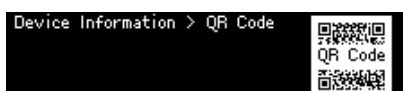

MAC Address

This displays the MAC address.



Serial No.

This displays the serial number.

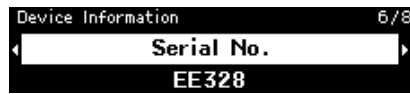

Dante Version

This displays the version of the Dante firmware. From the left, the Dante firmware version, Dante hardware version and Yamaha software version are displayed.

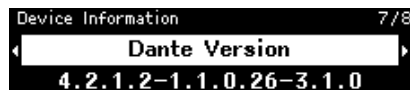

Firmware Version

This displays the version of the DME10 device firmware.



NOTE

- Update the firmware with ProVisionaire Design.
For details, refer to the ProVisionaire Design User Guide (HTML).
The latest firmware can also be downloaded from the download page of the Yamaha Pro Audio website.
<https://www.yamahaproaudio.com/>

Alert Log

This allows you to check the alert log recorded in the DME10. The log displays the alerts in the order that they occurred.

Up to 3000 alerts are saved.

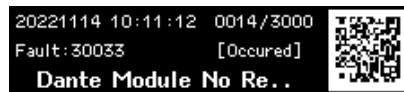
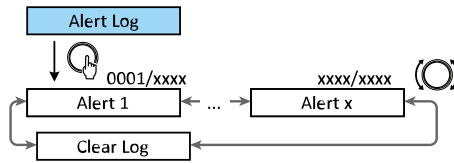

Clearing the log

The alert log can be cleared.

1. With the [Menu] screen displayed, turn the main knob to select [Alert Log], and then press the knob to confirm the selection.

The most recent alert appears.

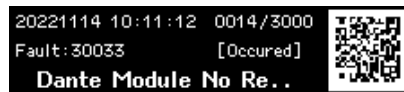

2. Display alert 0001, and then turn the main knob to the left. [Clear Log] appears.



3. When [Clear Log] is displayed, press the main knob to confirm the selection.

Utility

This allows you to specify general DME10 settings and check information.

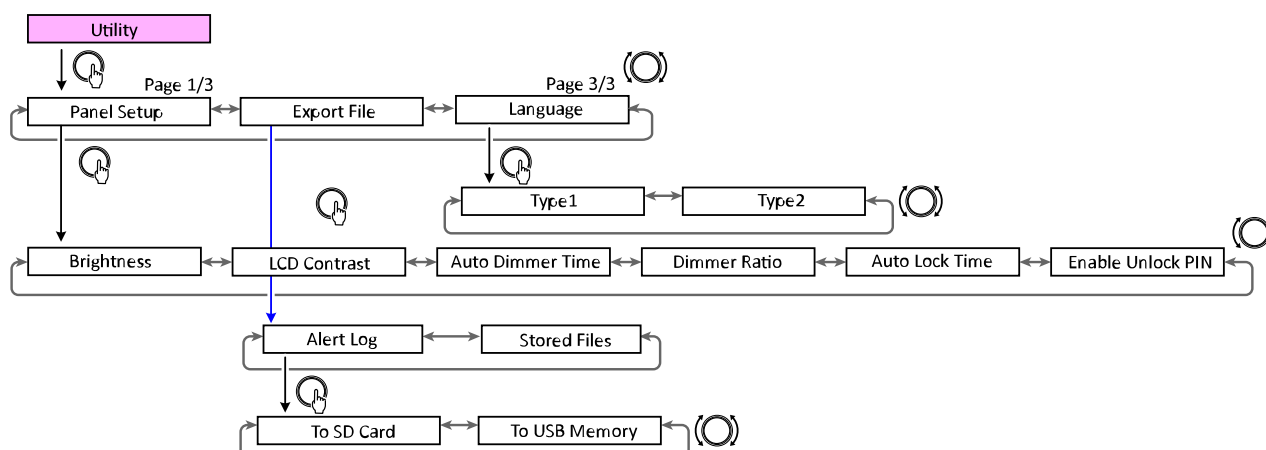

Panel Setup

Adjusting the brightness of the display (Brightness)

This allows you to adjust the brightness of the display backlight.



Adjusting the LCD contrast (LCD Contrast)

This allows you to adjust the display contrast.



Specifying the auto dimmer time (Auto Dimmer Time)

This allows you to specify the length of time (after this device has not been operated for a certain period of time) for the display to reach the brightness specified with [Dimmer Ratio].
Select from [10 sec], [30 sec], [1 min], [3 min], [30 min], and [Never].



NOTE

- Even after the display has been dimmed, it will return to its normal brightness when an alert occurs or during synchronization.

Specifying the dimmer ratio (Dimmer Ratio)

This allows you to specify the brightness of displays after this device has not been operated for a certain period of time.

Select a value between 0% (off) and 75%.

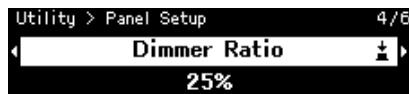

Specifying the auto lock time (Auto Lock Time)

This allows you to specify the length of time after this device has not been operated until the panel is automatically locked.

Select from [10 sec], [30 sec], [1 min], [3 min], [30 min], [1 hour], and [Never].



Specifying a PIN code for unlocking the panel (Enable Unlock PIN)

When this is set to [On], PIN code authentication is required in order to unlock the panel.

When this is changed from [Off] to [On], the PIN code input screen appears.



Exporting/saving (Export File)

Alert logs and project files can be saved to an SD memory card or USB flash drive. Project files can be transferred from ProVisionaire Design to the DME10 device.

1. Turn the main knob to select [Export File], and then press the knob to confirm the selection.



2. Turn the main knob to select the item to be saved, and then press the knob to confirm the selection. If an administrator PIN has been specified, type the PIN code into the PIN input screen that appears.



NOTE

- Administrator PIN is a code used to prevent the device settings from being modified via ProVisionaire Design. For details, refer to the ProVisionaire Design User Guide.

A screen to confirm the save destination appears. If you select a USB flash drive as the save destination, "To USB Memory" will appear instead.



NOTE

- At this time, "Not Inserted" appears at the bottom of the display if no media has been inserted, "Unsupported Format" if the media is not formatted or mounted, or "Write Protected" if the media is write-protected.

3. Turn the main knob to select the save destination, and then press the knob to confirm the selection. Follow the on-screen instructions to save the data.

NOTE

- Pressing the main knob during the export process stops the operation.

Selecting the language (Language)

You can select one of two language types.



Type1: Japanese kanji, hiragana, katakana, English, all European languages

Type2: Chinese characters, Japanese hiragana, katakana, English, all European languages

Dante Settings

This specifies settings related to the Dante network.

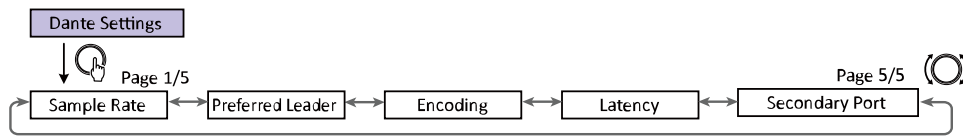

NOTE

- Settings in Dante Controller are changed in sync with the parameters in this [Dante Settings] screen.

Specifying the sampling frequency (Sample Rate)

This allows you to specify the Dante input/output sampling frequency. Select from [44.1 kHz], [48 kHz], [88.2 kHz], and [96 kHz].



Specifying the preferred leader (Preferred Leader)

Selecting [On] sets this device to be “Preferred Leader” (device supplying the leader clock). If more than one device is set to be “Preferred Leader”, the device with the lowest MAC address will be used.



Specifying the encoding (Encoding)

This allows you to specify the Encoding (number of quantization bits). Select from [24 bit] or [32 bit].



Specifying the latency (Latency)

This allows you to specify the latency for signals sent and received over a Dante network.

Select from [0.25 ms], [0.5 ms], [1 ms], [2 ms], and [5 ms].

The appropriate latency setting for signals sent and received over a Dante network differs depending on the connection method and scale.



Specifying the secondary port (Secondary Port)

Select [Redundant] or [Daisy Chain] for the connection method for the two Dante ports. After the setting is changed, a message appears, prompting you to restart this device.



 **NOTE**

- The setting is applied after this device is restarted.

Settings

This allows various settings for this device to be specified.

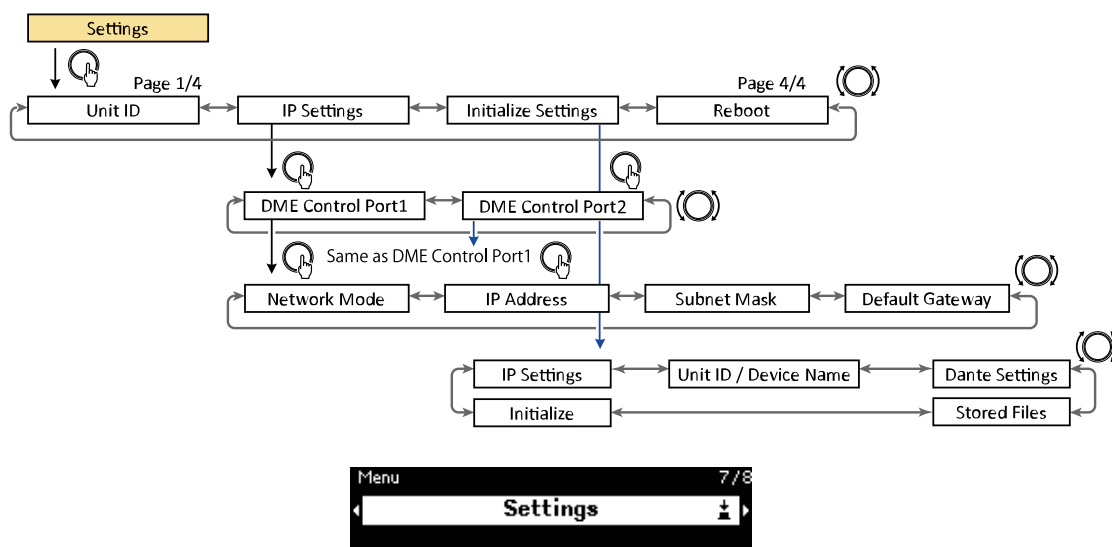

Specifying the unit ID (Unit ID)

This allows you to specify a unique ID for the DME10.

If multiple DME10 devices are used, make sure none of the unit IDs are the same.

1. With the [Unit ID] screen displayed, turn the main knob to enter edit mode.

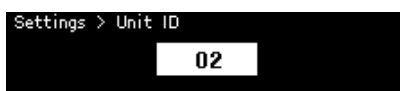

2. Turn the main knob to select an ID.
When the unit ID is changed, the setting flashes.
The value range is 01 to FE in hexadecimal.
3. After selecting the unit ID, press the main knob.

NOTE

- The specified unit ID is applied after this device is restarted.

Specifying the IP address (IP Settings)

This allows you to specify the IP address for the port (DME control port1, DME control port2) used to communicate with ProVisionaire Design. DME Control Port 1 corresponds to the network connector, and DME Control Port 2 corresponds to the Dante [PRIMARY] connector.

The DME10 device can be controlled by connecting ProVisionaire Design to either the network connector or the Dante [PRIMARY] connector.

Communication method	Connector used to control the parameters
(1) Superimposing a control signal onto a Dante audio signal <Dante>	Dante [PRIMARY] connector, Dante [SECONDARY] connector
(2) Using the Dante [PRIMARY] connector via network communications <Monitor, Remote>	Dante [PRIMARY] connector
(3) Using the network connector via network communications <Monitor, Remote>	network connector

Specifying the network mode (Network Mode)

This allows you to select the mode for setting the IP address of the DME10 manually or automatically (for example, by using a DHCP server).

NOTE

- For details on the modes, refer to the ProVisionaire Design User Guide.
- The IP address and network mode settings will take effect after you restart this device.



- If this is set to [DHCP], the IP address will be automatically specified by the DHCP server. If there is no DHCP server, no IP address will be specified.
- If this is set to [Static IP], select [IP Settings] > [DME Control Port1] > [IP Address]. Manually specify the IP address and subnet mask. Set the DME Control Port1 and DME Control Port2 addresses to different subnets.
- If this is set to [Unit ID], the IP address is specified based on the unit ID. This sets the IP address to 192.168.0.x (where “x” is the unit ID) and the subnet mask to 255.255.255.0. The IP address and subnet mask are both expressed in decimal format.

Displaying/specifying the subnet mask (Subnet Mask)

This displays the subnet mask. If [Static IP] was selected as the mode for specifying the IP address, this allows you to specify the subnet mask.



Displaying/specifying the default gateway (Default Gateway)

You can view and specify the default gateway.

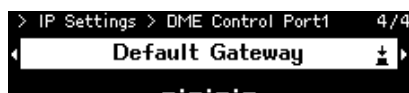

Restoring factory default settings (Initialize Settings)

This allows you to initialize all internal data.



NOTE

- For details on initializing, refer to ["Restoring factory default settings \(initializing\)"](#).

Restarting (Reboot)

This allows you to change multiple parameter settings that require a restart, then to reboot to apply all settings at once.



Snapshot Recall

In ProVisionaire Design, you can store (save) a snapshot of the parameter settings at a certain point in time, then recall them as necessary.

Use ProVisionaire Design to select the snapshots that will be available to be recalled to this device. Nothing will appear if nothing has been selected.

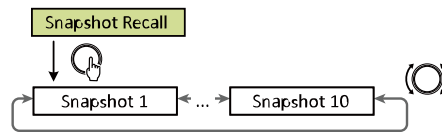

The number of snapshots will be the number sent from ProVisionaire Design.



1. Turn the main knob to select the snapshot to be recalled, and then press the knob to confirm the selection.

A screen appears, prompting you to confirm the recall.

 **NOTE**

- Do not switch off this device while a snapshot is being recalled.

After a snapshot has been recalled, it appears in the Home screen.

Restoring factory default settings (initializing)

There are two methods to initialize this device.

Method of selecting [Settings] > [Initialize Settings]

Do not switch off this device while it is being initialized.

1. With the [Menu] screen displayed, turn the main knob to select [Initialize Settings], and then press the knob to confirm the selection.



2. Turn the main knob to select an item to be initialized, and then set it to [On].



In addition to signal processing settings, the following settings are also initialized if set to [On].

- IP Settings
- Unit ID/ Device Name
- Dante Settings
- Stored Files

NOTE

- This regular initialization process does not initialize the administrator PIN or license activation information.

3. After selecting the desired settings, turn the main knob to select [Initialize], and then press the knob. This device automatically restarts when initialization is finished.

If you have forgotten your administrator PIN

If you cannot initialize the unit in the Settings screen because you have forgotten your administrator PIN or due to some other reason, follow the steps below to perform a forced initialization:



Notice

- This forced initialization process does not initialize license activation information, but returns all other parameters to their factory default settings.

1. **While holding down the [Fn], [MENU/HOME] and [↵] (back) buttons, switch on this device.**
2. **Keep holding down the three buttons until the NEXO logo and the initialization screen appear in the display.**

This device automatically restarts when initialization is finished.

Appendix

Precautions for the USB port

• USB devices that can be used

- Use a USB flash drive. Other USB devices (USB hubs, mice, computer keyboards, etc.) cannot be used even if they can be connected.
- USB 1.1 to 2.0 USB flash drives can be used with this device (however, operation of all USB flash drives is not guaranteed).

The rating of the USB port is a maximum of 5 V/500 mA. Connecting a device that requires more than 500 mA of current will stop the power supply to this device.

• Connecting a USB flash drive

- Do not remove or install the USB flash drive while data is being written to it. Otherwise, this device may stop functioning, or the USB flash drive or its data may become corrupted.
- Before installing the USB flash drive again after removing it, wait a few seconds.



Notice

- When using a USB extension cable, be sure that it is 1 m or less.

Using USB flash drives

• Formatting a USB flash drive

Use a USB flash drive formatted to FAT32 or FAT16. Use a computer to format. USB flash drives formatted with other devices may not work properly with this device.

• Preventing accidental data loss

Some USB flash drives have a write-protect function to prevent accidental deletion of data. If the USB flash drive contains important data, write-protect it to prevent overwriting. Likewise, before adding data to the USB flash drive, for example, be sure to remove write protection.

• Switching off this device with a USB flash drive installed

Do not switch off this device while data is being written. Otherwise, the USB flash drive or its data may become corrupted.

Precautions for using SD memory cards

● SD memory cards that can be used

- Use memory cards with the SD or SDHC format. (The SDXC format is not supported).

● Supported file specifications

WAV files

File extension .wav only.

Sampling rates of 44.1 kHz, 48 kHz, 88.2 kHz and 96 kHz are supported.
16-bit, 24-bit and 32-bit PCM monaural and stereo are supported.

MP3 files

Only one MPEG audio is supported.

Layer III is supported (only extension .mp3); free format is excluded.

Sampling rates of 32 kHz, 44.1 kHz and 48 kHz are supported.
Bit rates of 32 to 320 kbps and VBR (variable bit rate) are supported.

● Inserting an SD memory card

- Do not insert or remove the SD memory card while the SD/ACT indicator is lit. Otherwise, this device may stop functioning, or the SD memory card or its data may become corrupted.
- Before inserting the SD memory card again after removing it, wait a few seconds.

Using SD memory cards

● Formatting an SD memory card

- Use an SD memory card formatted to FAT16 for SD or formatted to FAT32 for SDHC. Use a computer to format. SD memory cards formatted with other devices may not work properly with this device.

● Preventing accidental data loss

- SD memory cards have a locking switch to prevent accidental deletion of data. If the SD memory card contains important data, lock it to prevent overwriting. Likewise, before adding data to the SD memory card, for example, be sure to unlock it.

● Switching off this device with an SD memory card inserted

- Before switching off this device, make sure that the SD/ACT indicator is not lit. Otherwise, the SD memory card or its data may become corrupted.

Distance to furthest DCP control panel

The distance from the DME10 to the furthest DCP control panel depends on the number of connected DCPs.

Example 1. When there are 8 DCP devices

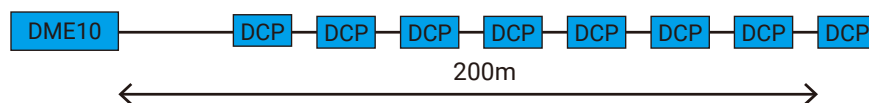

Example 2. When there are 2 DCP devices

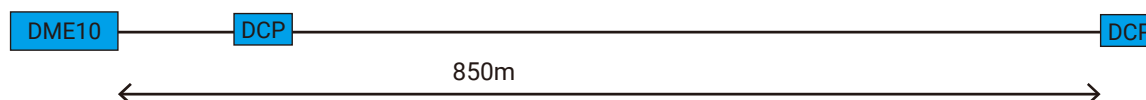

For the relationship between the number of connected devices and the distance, refer to the following table.

No. of connected DCPs	Distance from DME10 to furthest DCPs
1	1000 m
2	850 m
3	550 m
4	400 m
5	350 m
6	250 m
7	250 m
8	200 m

NOTE

- Use a DCH8, a digital controller hub, to make a star connection.

Message List

Messages displayed on the DME10 display and countermeasures are as follows.

Data ID	Data Name	Message [Normal]	Message [Warning]	Message [Error]	Message [Fault]
30002	EXT TEMP Limit	-	Environmental temperature exceeded device upper limit. Please check air flow.	-	-
30009	FAN Rotation Error	-	FAN rotation speed out of control. Please check that fan rotation is not obstructed by some external impediment.	-	FAN stopped. Please contact NEXO service personnel.
30010	Fan Lifespan Warning	-	FAN will soon reach end of expected lifespan. Please contact NEXO service personnel.	-	-
30011	Low Battery	-	Remaining battery charge is low. Please replace.	Battery charge will soon be exhausted. Please replace.	No battery charge remaining. Some part of data cannot be preserved correctly.
30022	Leader W/C Unlock	-	-	Wrong word clock detected on leader word clock source.	-
30024	Storage Lifespan Warning	-	Storage device will soon reach end of expected lifespan. Please contact NEXO service personnel.	-	-
30025	Storage Access Error	-	Error occurred whilst writing data to storage.	-	Error occurred while writing data to storage. Please contact NEXO service personnel.
30026	IP Address Duplicate	-	-	IP Address collision detected.	-

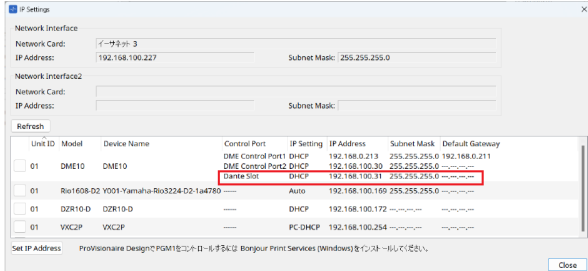
Data ID	Data Name	Message [Normal]	Message [Warning]	Message [Error]	Message [Fault]
30033	Dante Module Error	-	-	-	Dante module is not responding. Refer to the following.
<p>Make sure that Dante Slot and the Dante module are on the same network. If they are not on the same network, communication between Dante Slot and the Dante module will not be possible. Set the IP address appropriately using the following method. If the problem persists, please contact NEXO service personnel.</p> <p>You can check the IP address of Dante Slot using ProVisionaire Design and the IP address of the Dante module using Dante Controller. Refer to the Dante Controller User Guide for instructions on how to check the IP address of the Dante module.</p> <p>ProVisionaire Design</p>  <p>The screenshot shows the 'IP Settings' window in ProVisionaire Design. It has two sections for 'Network Interface 1' and 'Network Interface 2'. Below these is a table with columns: Unit ID, Model, Device Name, Control Port, IP Setting, IP Address, Subnet Mask, and Default Gateway. The table contains several entries, with the 'Dante Slot' entry highlighted in red. The 'Dante Slot' entry shows 'DME Control Port 2' as the control port, 'DHCP' as the IP setting, and '192.168.100.31' as the IP address with a subnet mask of '255.255.255.0'.</p> <ol style="list-style-type: none"> In Dante Controller, set the Dante IP of the DME device to DHCP mode. <ul style="list-style-type: none"> → If a DHCP server is available, the IP address is set automatically. → If no DHCP server is available, 169.254.xxx.xxx is assigned (link-local address). Apply the setting and reboot the device. The parameters will not be reflected unless the DME device is rebooted. Properly configure the NIC on your computer. <ul style="list-style-type: none"> → If a DHCP server is available, the IP address is set automatically. → If no DHCP server is available, set the IP address to 169.254.xxx.xxx. <p>Be careful not to cause conflicts within the network.</p> Configure the NIC of Dante Slot in ProVisionaire Design. <ul style="list-style-type: none"> → If a DHCP server is available, the IP address is set automatically. → If no DHCP server is available, set the IP address to 169.254.xxx.xxx. <p>Be careful not to cause conflicts within the network.</p> <p>After the setting is changed, the DME device will reboot automatically.</p> Check that the device has rebooted. The parameters will not be reflected unless the device is rebooted. <p>When setting up using a single LAN cable, connect ProVisionaire Design to the Dante [Primary] connector and set DME Control Port 2 to DHCP mode.</p>					
30034	No Dante Connection	-	No network is connected to the Dante port. Please check the Dante connection.	-	-

Data ID	Data Name	Message [Normal]	Message [Warning]	Message [Error]	Message [Fault]
30037	Wrong Dante Clock	-	Dante word clock settings are wrong. Please check the settings.	-	-
30038	Muted - Dante Clock Err.	-	-	Muted due to incorrect Dante word clock settings. Please check Dante word clock settings.	-
30039	Dante Clock Offset Err.	-	Dante Clock Frequency Offset is unstable. Please check network configuration including Ethernet switch settings.	-	-
30040	Dante Redundancy Triiggered	-	Dante Audio transmission has switched to Secondary network.	-	-
30041	Dante Secondary Error	-	The Dante secondary port is not functioning.	-	-
30047	Power ON	Power ON	-	-	-
30049	Device Initialized	Memory initialization performed.	-	-	-
30050	Time Synchronized	Date and time is synchronized.	-	-	-
30051	Firmware Updated	Firmware update performed.	-	-	-
30052	Scene/Snapshot Store	Scene/Snapshot store performed.	-	-	-
30053	Scene/Snapshot Recall	Scene/Snapshot recall performed.	-	-	-
30056	PSU Switched Over	-	Either Redundant Power Supply "A" or "B" failed. Please check power cables and source.	-	-

Data ID	Data Name	Message [Normal]	Message [Warning]	Message [Error]	Message [Fault]
30057	Dante Link 100Mbps	-	Dante link speed is less than Gigabit. Try plugging into a different network switch or a different port. Alternatively, try using a different network cable.	-	-
30058	Sub Module Error	-	-	-	Internal sub module is not responding. Please contact NEXO service personnel.
30059	Sub Module Rebooted	-	-	Internal sub module has rebooted unintentionally.	-
30060	Illegal MAC address	-	-	-	Illegal MAC address has been detected at control ethernet interface. Please contact NEXO service personnel.
30061	Dante MAC Address Err.	-	-	-	Illegal MAC address has been detected at Dante ethernet interface. Please contact NEXO service personnel.
30062	IP Address Assigned	IP address is assigned to the network interface.	-	-	-
30063	IP Address Assigned (Auto IP)	IP address is assigned (AutoIP) to the network interface.	-	-	-
30064	IP Address Released	IP address assigned by DHCP server is released.	-	-	-
30065	Internal Network Error	-	-	Unable to establish connection with internal sub module due to incorrect network address.	-

Data ID	Data Name	Message [Normal]	Message [Warning]	Message [Error]	Message [Fault]
30066	Dante (TX) Overflow	-	-	Dante Audio Flow Resource (TX) exceeded. Please re-design Dante patch to match Dante Flow resources.	-
30067	Dante (RX) Overflow	-	-	Dante Audio Flow Resource (RX) exceeded. Please re-design Dante patch to match Dante Flow resources.	-
30068	Dante Settings Locked	-	Unable to apply Dante setting changes to the Dante module due to Dante Device Lock or DDM permission settings.	-	-
30069	DCP Comms Error	-	-	Communication error is detected during the communication sequence between host device and DCPs. Please make sure that the following are within specification: 1) cable length, 2) cable quality, 3) the final DCP in the chain is terminated.	-
30070	DCP Configuration Error	-	-	Unable to communicate with connected DCPs correctly. Please check if 1) Panel ID's are correctly set 2) Pre-configured DCP type and real DCP type connected by wire is identical.	-

Data ID	Data Name	Message [Normal]	Message [Warning]	Message [Error]	Message [Fault]
30071	DSP Resource Overflow	-	-	The resource for audio signal processing is unexpectedly overflowed, which might cause audible noise.	-
30072	Incompatible Data/File	-	-	Unable to Load/Import Data/File due to incompatible data format.	-
30073	Incompatible RC Protocol	-	-	Unable to communicate/respond to external remote control device/software due to incompatible protocol version.	-
30074	DHCP Server No Response	-	-	DHCP server is not responding to the device.	-
30075	NTP Server No Response	-	-	NTP server is not responding to the device.	-
30076	Missing License	-	-	Some or entire functions of this device stop working due to missing or insufficient licenses. Please activate additional licenses or remove corresponding functions.	-
30077	Setting Data Corrupted/Lost	-	-	Corrupted data/file is detected.	-
30078	Storage Full	-	-	Storage Full.	-
30079	Unsupported File System	-	-	The storage drive is formatted with unsupported file system type. Please re-format the storage to a supported format.	-
30080	Removable Drive Mounted	Removal drive has been mounted to device.	-	-	-

Data ID	Data Name	Message [Normal]	Message [Warning]	Message [Error]	Message [Fault]
30081	Removable Drive Unmounted	Removal drive has been unmounted from device.	-	-	-
30082	File Not Found	The file cannot be found.	-	-	-
30083	Authentication Failed	-	Wrong PIN code/Password was entered.	-	-
30084	Panel Locked	The operation panel is locked.	-	-	-
30085	Panel Unlocked	The operation panel is unlocked.	-	-	-
30086	Scene/Snapshot Recall Failed	-	-	Failed to recall the Scene/Snapshot data.	-
30087	Data Sync Failed	-	-	Synchronization sequence has been stopped unexpectedly.	-

General specifications

Internal processing		44.1/48/88.2/96 kHz
Memory		Parameter sets: 1,000 Snapshots: 10,000
Cooling		Fan included
Fan noise		NC20 (1 m from front panel)
Dante interface	Channel count	256IN, 256OUT, redundant
	Sampling frequency	44.1/48/88.2/96 kHz
	Bit depth	24/32 bits
USB audio	Channel count	8 inputs, 8 outputs with SRC
	Sampling frequency	44.1/48/88.2/96 kHz
Connectors	Dante	etherCON × 2 (PRIMARY/SECONDARY) 1000Base-T
	DCP	RJ45 × 1
	USB TO HOST	USB 2.0 Type-C connector for USB audio
	USB TO DEVICE	USB 2.0 Standard-A Connector for Save/Load
	Network	RJ45 × 1 100Base-TX
	GPIO	Euroblock 16 terminals (mini) × 2 (GPI x16, GPO x8, +5V power x4)
	MIDI	DIN 5 pin x2 (IN, OUT)
	AC IN	AC inlet (IEC, V-Lock) x2
Memory device specifications	Compatible formats	FAT32, FAT16, FAT12
	Supported capacity	SDHC: Maximum 32 GB SD: Maximum 2 GB
	Maximum file size	FAT12: Maximum 32 MB FAT16: Maximum 2 GB FAT32: Maximum 4 GB
Controls	Front panel	Rotary encoder and buttons for GUI control Operation lock feature
	Display	224 × 48 pixels, mono color with brightness adjustment
AC power requirement		100 V-240 V 50 Hz/60 Hz
Power consumption		100 W
Heat dissipation		86.3 kcal/h

Operating temperature	0 °C to +40 °C
Storage temperature	-20 °C to +60 °C
Dimensions (W × H × D)	480 x 132 x 363 mm (18.90 x 5.20 x 14.29 inch)
Weight	9.5 kg
Rack mount condition	No restrictions
Finish	Front panel: Aluminum (silver+black) Munsell approximate value N9 (silver)+N2.5 (black) Handle: Metal (black paint)
Included items	One Setup Guide Two Euroblock plugs (16-pin, 3.50 mm pitch) Two power cords One cable hook
Separately sold items	DCP4V4S-US/EU DCP1V4S-US/EU DCP4S-US/EU DCH8
Expansion license	NX-AFC-I

Dimensions

Units: mm

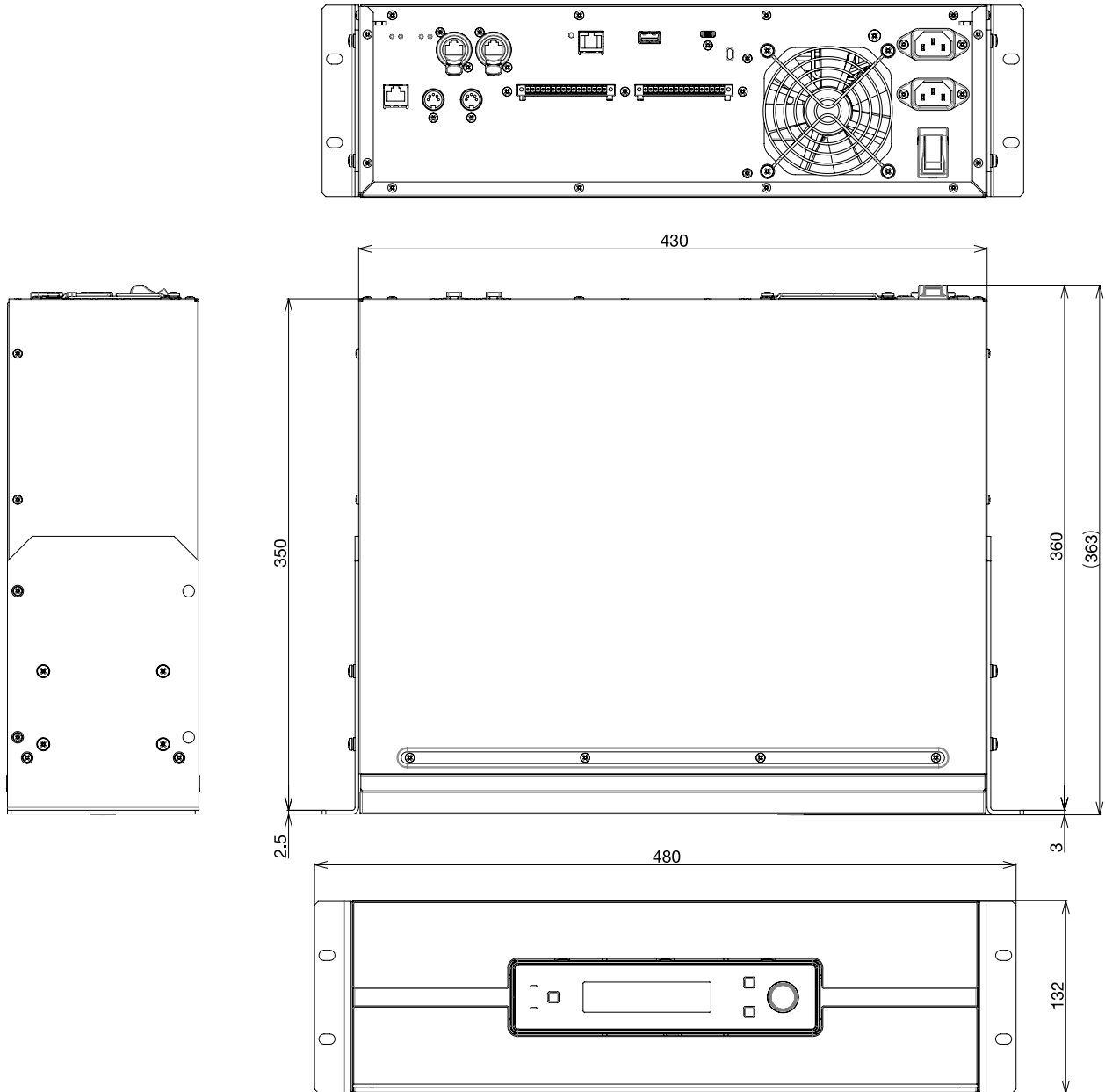

Block diagram

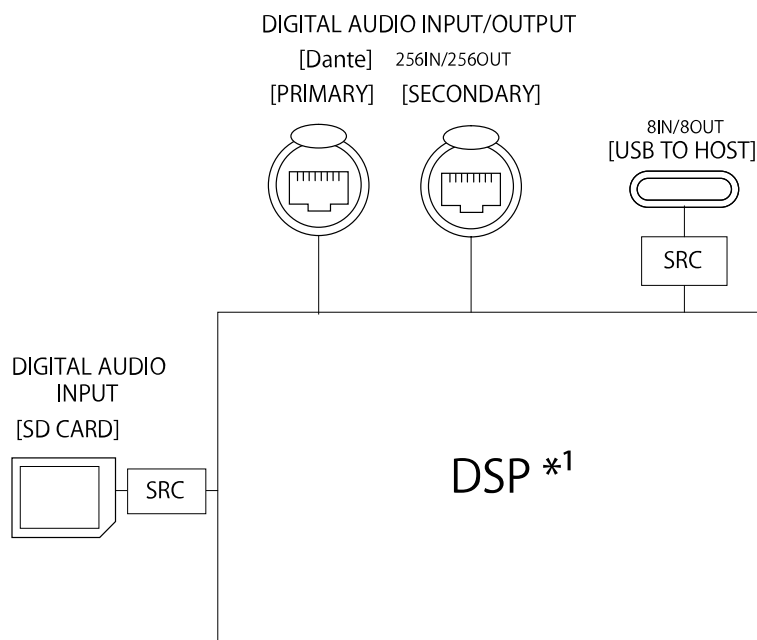

*1 Highly configurable, see a separate list "ProVisionaire Design Component Guide" for supported components.
https://manual.yamaha.com/pa/pv/pvd_cg/

This document is based on the latest specifications at the time of publication. The latest version can be downloaded from the NEXO website.

